

Assembly and operating instructions

DULCO® turb C Turbidity sensor

ProMinent®



A0652

**Please carefully read these operating instructions before use! · Do not discard!
The operator shall be liable for any damage caused by installation or operating errors!
Technical changes reserved.**

ProMinent Dosiertechnik Heidelberg GmbH

Im Schuhmachergewann 5 - 11

69123 Heidelberg

Telephone: +49 6221 842-0

Fax: +49 6221 842-419

email: info@prominent.de

Internet: www.prominent.com

986062, 1, en_GB

General non-discriminatory approach

In order to make it easier to read, this document uses the male form in grammatical structures but with an implied neutral sense. It is aimed equally at both men and women. We kindly ask female readers for their understanding in this simplification of the text.

Safety information are provided with detailed descriptions of the endangering situation, see  *Chapter 1.1 „Explanation of the safety information“ on page 6*

Supplementary information

Read the following supplementary information in its entirety!

The following are highlighted separately in the document:

- Enumerated lists
- ➔ Instructions
 - ⇒ Results of the instructions

Information



This provides important information relating to the correct operation of the system or is intended to make your work easier.

Safety information

Table of contents

1	Introduction	6
	1.1 Explanation of the safety information.....	6
	1.2 Users' qualifications.....	8
2	Safety and responsibility	10
	2.1 General safety information	10
	2.2 Correct and proper use.....	11
3	Functional description / product identification	12
	3.1 Scope of delivery.....	16
4	Mounting and Installation	17
	4.1 Wall mounting.....	18
	4.2 Installation (hydraulic).....	21
	4.3 Installation (electrical).....	23
5	Operating diagram	26
	5.1 Overview of device /Control elements.....	26
	5.2 Overview of operating structure.....	27
6	Commissioning	30
	6.1 Load drying agent.....	30
	6.2 Routine measurement.....	33
	6.3 Access code.....	34
	6.4 Device configuration.....	35
	6.4.1 Selecting the output.....	35
	6.4.2 Configuration of fault current (ERLV).....	37
	6.4.3 Configure alarm	38
	6.4.4 OFFSET configuration.....	41
	6.4.5 Extended settings.....	43
7	Operation	55
	7.1 Calibrate sensor.....	55
	7.1.1 Standard solutions for calibration.....	55

7.1.2	Perform calibration.....	59
8	Maintenance, troubleshooting and repair.....	66
8.1	Information about fault maintenance.....	66
8.1.1	System error messages.....	67
8.1.2	Faults in the process.....	67
9	Spare parts and accessories.....	69
10	Standards complied with.....	70
11	Disposal of used parts.....	71
12	Declaration of Conformity.....	72
13	Index.....	73

1 Introduction

Data and functions

This operating manual provides information on the technical data and functions of the DULCO® turb C turbidity sensor.

1.1 Explanation of the safety information

Introduction

These operating instructions provide information on the technical data and functions of the product. These operating instructions provide detailed safety information and are provided as clear step-by-step instructions.

The safety information and notes are categorised according to the following scheme. A number of different symbols are used to denote different situations. The symbols shown here serve only as examples.

DANGER!

Nature and source of the danger

Consequence: Fatal or very serious injuries.

Measure to be taken to avoid this danger

Danger!

- Denotes an immediate threatening danger. If this is disregarded, it will result in fatal or very serious injuries.

WARNING!

Nature and source of the danger

Possible consequence: Fatal or very serious injuries.

Measure to be taken to avoid this danger

Warning!

- Denotes a possibly hazardous situation. If this is disregarded, it could result in fatal or very serious injuries.



CAUTION!

Nature and source of the danger

Possible consequence: Slight or minor injuries, material damage.

Measure to be taken to avoid this danger

Caution!

- Denotes a possibly hazardous situation. If this is disregarded, it could result in slight or minor injuries. May also be used as a warning about material damage.



Type of information

Hints on use and additional information

Source of the information, additional measures

Information!

- *Denotes hints on use and other useful information. It does not indicate a hazardous or damaging situation.*



NOTICE!

Nature and source of the danger

Damage to the product or its surroundings

Measure to be taken to avoid this danger

Note!

- Denotes a possibly damaging situation. If this is disregarded, the product or an object in its vicinity could be damaged.

1.2 Users' qualifications

WARNING!

Danger of injury with inadequately qualified personnel!

The operator of the plant / device is responsible for ensuring that the qualifications are fulfilled.

If inadequately qualified personnel work on the unit or loiter in the hazard zone of the unit, this could result in dangers that could cause serious injuries and material damage.

- All work on the unit should therefore only be conducted by qualified personnel.
- Unqualified personnel should be kept away from the hazard zone

Training	Definition
Instructed personnel	An instructed person is deemed to be a person who has been instructed and, if required, trained in the tasks assigned to him/her and possible dangers that could result from improper behaviour, as well as having been instructed in the required protective equipment and protective measures.
Trained user	A trained user is a person who fulfils the requirements made of an instructed person and who has also received additional training specific to the system from ProMinent or another authorised distribution partner.
Trained qualified personnel	A qualified employee is deemed to be a person who is able to assess the tasks assigned to him and recognize possible hazards based on his/her training, knowledge and experience, as well as knowledge of pertinent regulations. The assessment of a person's technical training can also be based on several years of work in the relevant field.

Training	Definition
Electrician	<p>Electricians are deemed to be people, who are able to complete work on electrical systems and recognize and avoid possible hazards independently based on his/her technical training and experience, as well as knowledge of pertinent standards and regulations.</p> <p>Electricians should be specifically trained for the working environment in which they are employed and know the relevant standards and regulations.</p> <p>Electricians must comply with the provisions of the applicable statutory directives on accident prevention.</p>
Customer Service department	Customer Service department refers to service technicians, who have received proven training and have been authorised by ProMinent to work on the system.



Note for the system operator

The pertinent accident prevention regulations, as well as all other generally acknowledged safety regulations, must be adhered to!

2 Safety and responsibility

2.1 General safety information

 **WARNING!****Live parts!**

Possible consequence: Fatal or very serious injuries

- Measure: Disconnect the mains power supply prior to opening the housing
- Disconnect damaged, defective or manipulated devices from the power supply

 **WARNING!****Unauthorised access!**

Possible consequence: Fatal or very serious injuries.

- Measure: Ensure that there can be no unauthorised access to the unit

 **WARNING!****Operating errors!**

Possible consequence: Fatal or very serious injuries.

- The unit should only be operated by adequately qualified and technically expert personnel
- Please also observe the operating instructions for controllers and fittings and any other component groups, such as sensors, sample water pumps ...
- The operator is responsible for ensuring that personnel are qualified

 **CAUTION!****Electronic malfunctions**

Possible consequence: Material damage right through to destruction of the unit

- The mains connection cable and data cable should not be laid together with cables that are prone to interference
- Measure: Take appropriate interference suppression measures

! NOTICE!

Correct and proper use

Damage to the product or its surroundings

- The unit is not intended to measure or regulate gaseous or solid media
- The unit may only be used in accordance with the technical details and specifications provided in these operating instructions and in the operating instructions for the individual components

! NOTICE!

Correct sensor operation

Damage to the product or its surroundings

- Correct measuring and control is only possible if the sensor is working perfectly
- Check and calibrate the sensor regularly

2.2 Correct and proper use

! NOTICE!

Correct and proper use

The device is designed to measure the turbidity of water.

The unit may only be used in accordance with the technical details and specifications provided in this operating manual and in the operating manuals for the individual components (such as, for example, controllers, sensors, fittings, calibration devices, metering pumps, etc.).

Any other uses or modifications are prohibited.

3 Functional description / product identification

Brief functional description

The DULCO® turb C is designed for the online measuring of turbidity in untreated water, process water and treated process water in drinking water processing plants.

The DULCO® turb C product range is comprised of four device types:

Types TUC 1 and TUC 3 work with infrared light and fulfil the requirements of the international standards ISO 7027 and DIN EN 27027.

Types TUC 2 and TUC 4 work with white light and fulfil USA standard US EPA 180.1.

Both device types can be equipped with ultrasonic cleaning (TUC 3 / TUC 4) or without ultrasonic cleaning (TUC 1 / TUC 2). The sample cell ultrasonic cleaning system extends the calibration and maintenance intervals in media where coating formation is common.

DULCO® turb C	Part number	IOS 7027 DIN EN 27027	US EPA 180.1	Ultrasonic cleaning
TUC 1	1037696	Infrared		No
TUC 2	1037695		White light	No
TUC 3	1037698	Infrared		Yes
TUC 4	1037697		White light	Yes

An inlet side pressure regulating valve is standard. The DULCO turb C pressure regulating valve reduces the pressure from up to 13.8 bar (200 PSI) to 1.0 bar (15 PSI).

Specifications

Measuring range	0 – 1000.0 NTU
Accuracy limit	± 2 % of the displayed value or ± 0.02 NTU under 40 NTU, depending on which value is the greater. ± 5 % of the displayed value above 40 NTU
Resolution	0.0001 NTU below 10 NTU
Response time	configurable
Display	Multiple row LCD display with backlighting
Alarm	Two programmable alarms, 120 - 240 VAC, 2 A Form C relay
Analogue output	4 ... 20 mA, 600 Ω
Communication interface	Bi-directional RS-485, Modbus
Maximum water pressure	Integrated pressure regulating valve regulates 1380 kPa (200 PSI). in relation to the flow rate
Flow rate	6 l/h ... 60 l/h
Operating temperature	1 °C ... 50 °C

Functional description / product identification

Materials that come into contact with the media	Polyimide (PA), silicone, polypropylene (PP), stainless steel, borosilicate glass
Voltage supply	100 – 240 VAC, 47 – 63 Hz, 80VA
Galvanic Isolation	dual insulation, degree of interference overvoltage category II
Ambient conditions	Not suitable for operation outdoors. Operation altitude maximum 2000 m (above sea level). maximum 95 % relative air humidity (non-condensing).
Enclosure rating	IP 66
Standards compliant with	USEPA 180.1 for type „Infrared“, ISO 7027 and DIN EN 27027 for type „White light“
Shipping weight	approx. 2.5 kg

Option: ultrasonic cleaning (TUC 3 / TUC 4)

The „*Ultrasonic cleaning*“ option is used in order to continuously clean the sample chamber. It serves neither to clean previously soiled sample chambers, nor can it replace manual cleaning. However, the cleaning intervals for manual cleaning can be significantly extended by the use of this system. The use of a sample chamber with an „*ultrasound transducer*“ is necessary in order to

operate the system. The system emits an ultrasonic frequency via a spring to a piezoelectric transducer, which is connected to the base of the flow-through cuvette. The cuvette's detection system only works in *[AUTO mode]*.

The system can detect the following fault states:

- Incorrect cuvette installed
- Error occurred in transducer
- Transducer has no contact to the spring

If an error occurs, the message *[CLN]* appears in the lower part of the LCD display. An alarm is triggered and 2 mA is applied to the current output.

The alarm relay is triggered if the alarm funktion in *[ALM1/ALM2]* is set to *[ERROR]*

The 4 ... 20 mA output is set to 0, 2, 4 mA if the funktion *[error level] [ERLV]* was set to the corresponding mA-level.

Interface RS-485

The DULCO® turb C offers basic communications functions in combination with straightforward applications, such as *[Hilgraeve HyperTerminal]* (included with most *[Microsoft Windows software]* packages). In addition, you can also use *[Visual Basic]* as well as other programs.

3.1 Scope of delivery



Packaging material

Dispose of packaging material environmentally. All packaging components are provided with their corresponding recycling  code.

The following components are included as standard with a DULCO® turb C:

Description	Quantity
DULCO® turb C with terminal boxes and integrated und flow fittings	1
Operating Manual	1
Packet drying agent	1
Cuvette	1
Hose kit	1
■ Shut-off clamp (1 piece)	
■ Back-pressure valve (1 piece)	
■ Connection hoses with connection pieces for pressure regulating valves (2 pieces)	
■ Bleed screw (used in pressurised systems) (1 piece)	

Remove the DULCO® turb C from the packaging. Carefully check the components. Ensure that no visible damage has been caused during shipping. If the components supplied fail to comply with the order, please contact your local distributor or the ProMinent customer services department immediately.

4 Mounting and Installation

! NOTICE!

Drying agent

Possible device malfunctions due to moisture in the device.

Install the drying agent bag before initial commissioning, see  Chapter 6.1 „Load drying agent“ on page 30

! NOTICE!

Mounting position and conditions

- The installation (electrical) may only take place after mounting (mechanical)
- Ensure that there is unimpeded access for operation
- Ensure for secure and vibration-free fastening.
- Avoid direct sunlight
- Permissible ambient temperature for the sensor at fitting position: 1 ... 50°C at max. 95% relative air humidity (non-condensing)
- Consider the permissible ambient temperature and the connected components

Reading and operating position

- *Install the device in a favourable position for reading and operating (preferably at eye level)*

Mounting position

- *Leave sufficient free space for the cables and necessary work*

Packaging material

Dispose of packaging material environmentally. All packaging components are provided with their corresponding recycling  code.

4.1 Wall mounting

Installation (mechanical)

NOTICE!

Distance to the sampling site

Install the sensor no further than maximum 3 meters from the sampling site. This is the only way to ensure a quick response time from the system.

Free space above the sensor

Allow for at least 200mm free space above the sensor for all required work on the sensor.

Fasten the sensor with four M6 screws and the terminal box with two M4 screws.

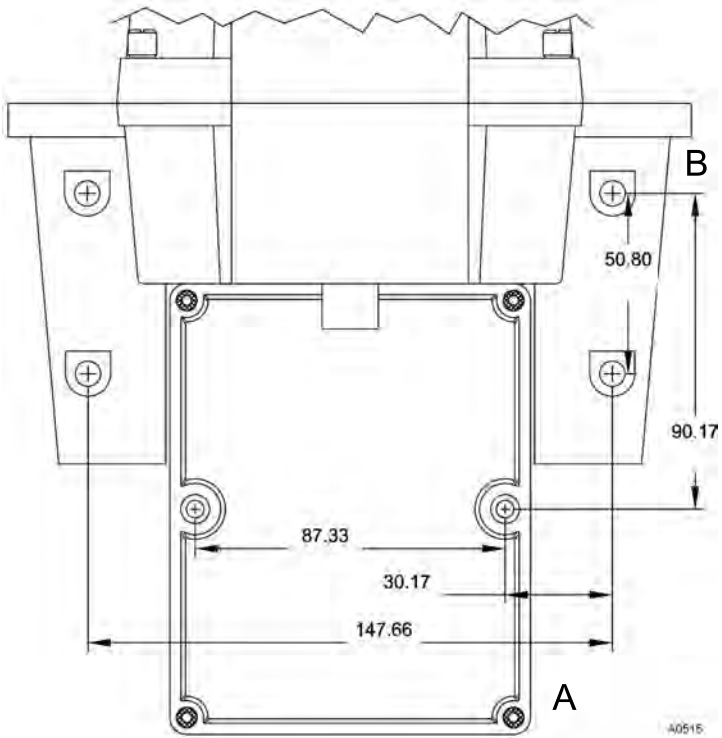

Fig. 1: The diagram is not to scale. It is for information only. All values given in millimetres.

- A Terminal box
- B DULCO® turb C housing

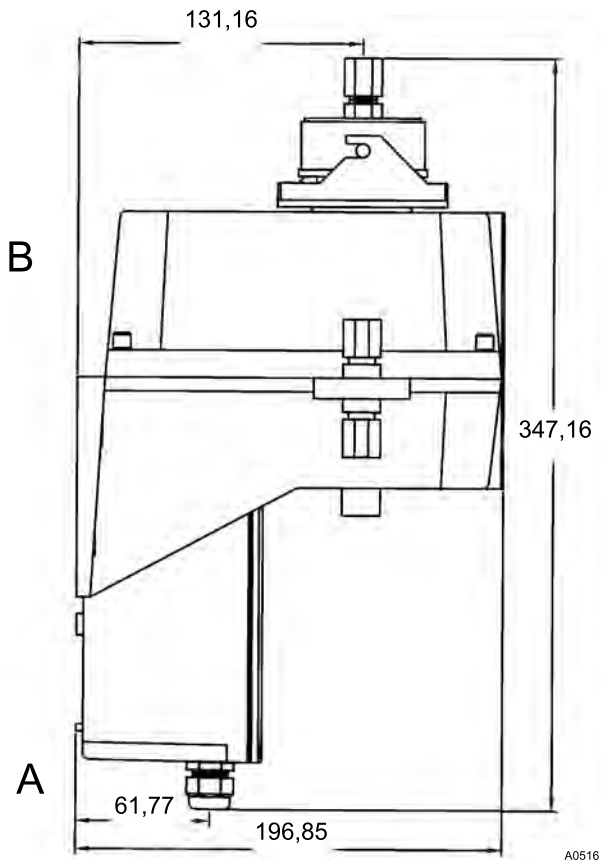

Fig. 2: The diagram is not to scale. It is for information only. All values given in millimetres.

- A Terminal box
- B DULCO® turb C housing

1. ➤ Fasten the terminal box (A) to the wall with two M4 screws
2. ➤ Fasten the DULCO® turb C housing (B) above the terminal box to the wall with four M6 screws

4.2 Installation (hydraulic)



CAUTION!

Free outlet at sensor outlet

Feed the sample water which has flowed through the sensor to a free drain. The sampled water may not be fed back into the process.



CAUTION!

Algae growth under the influence of light

Possible algae growth if unsuitable hoses are used.

Do not use transparent hoses if the installation is subjected to powerful sources of light. This prevents the formation of algae in the installation.



Leakage on the bleed screw

Slight leakage may occur at the bore hole for the bleed screw during the installation process. This will cease as soon as normal flow is established.

In the event that the installation continues to leak permanently at this point due to the high pressure in this area, we recommend sealing off the bore hole with the sealing plug supplied. In order to ensure free drainage, a bleed option must be installed at another area of the outlet in order to avoid overpressure or underpressure in the system.



Permissible operating parameters

- *Maximum liquid temperature 50 °C*
- *Maximum pressure 13.8 bar*
- *Flow rate 6 ... 60 l/h*

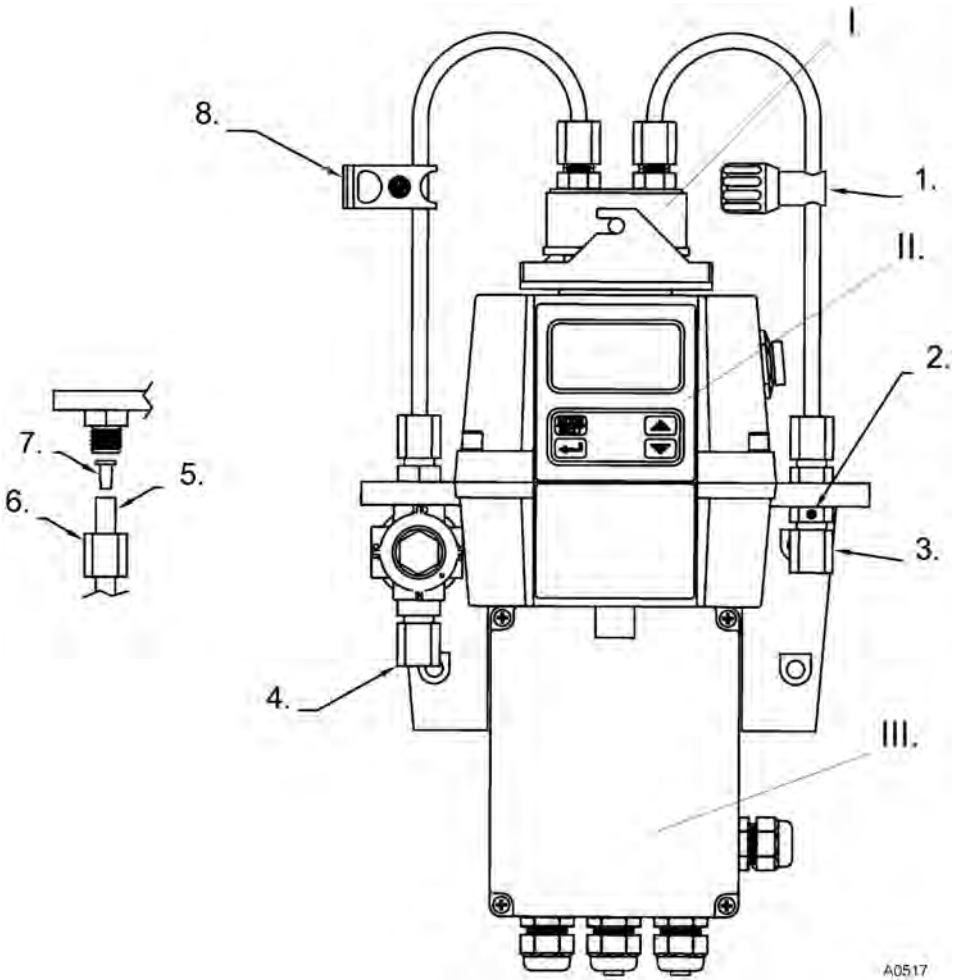

A0517

Fig. 3: Recommended pipes for the sensor

- | | | | |
|------|---|----|---|
| I. | Flow unit | 4. | Hose connector. 4.75 mm interior diameter, 8 mm external diameter. Hose connection to the sampling site |
| II. | Sensor unit with operating unit | 5. | Detail: Hose |
| III. | Terminal box | 6. | Detail: Union nut hose connection |
| 1. | Backpressure valve. To regulate the flow and in order to remove small air bubbles | | |

2. Vent screw. For use on pressurised systems. Not used for pressureless systems
3. Hose connector. 4.75 mm interior diameter, 8 mm external diameter. Hose connection for free sample water outlet
7. Detail: Replacement hose connection
8. Shut-off clamp. To shut-off the inlet in an emergency or for necessary work

4.3 Installation (electrical)



WARNING!

Live parts!

Possible consequence: Fatal or very serious injuries

- Measure: Disconnect the power supply before opening the housing
- Disconnect damaged, defective or manipulated devices from the power supply
- The provision of a suitable isolating device (emergency-off switch, etc.) is the responsibility of the plant operator



The signal leads of the DULCO® turb C may not be routed alongside faulty cabling. Faults could lead to malfunctions in the DULCO® turb C.



NOTICE!

Do not route any RS-485 cables in the same cable duct as the power supply cable. This may result in major anomalies.

RS-485

The RS-485 digital interface (2 leads / half duplex) is characterised by a very high tolerance to electromagnetic interference due to the symmetrical signal transmission. This means that cable lengths of up to 900m can be used. The final device on a bus must be equipped with a 120 ohm resistor, in order to avoid signal overlapping.

In order to avoid damage, only separate and connect the RS-485 cable if the DULCO® turb C is switched off.

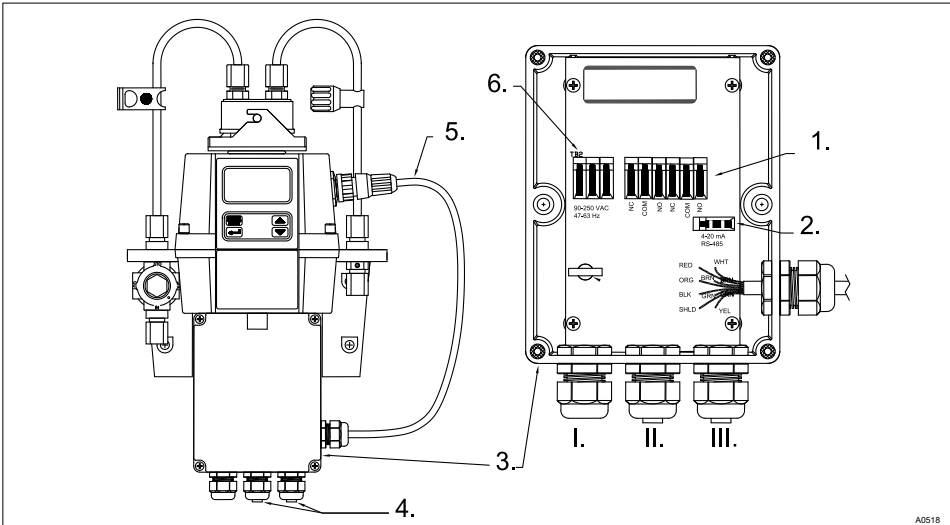

Fig. 4: Cable assignment of the sensor

- | | | | |
|------|---|----|--|
| I. | Power cable threaded connection (supplied without power cable) | 3. | Terminal box |
| II. | Alarm cable threaded connection | 4. | Liquid-tight threaded connection |
| III. | Sensor cable threaded connection | 5. | Sensor cable |
| 1. | Terminal Alarm 1 and Alarm 2 (0.25 - 1.5 mm ²) maximum 2 ampere | 6. | Terminal power cable (0.25 - 1.5 mm ²) |

2. Terminal 4-20 mA / RS 485 (0.25
- 1.5 mm²)



All terminals in the terminal box are labelled and are self-explanatory.

All cable bushings are equipped with blanks on shipping. These must be removed as required.

Strip the Insulation on all cables to a length of 6 mm.

Equip all cables with strain relief.

Supply voltage: 100 - 240 VAC at 47 - 63 Hz

1. ➤ Release the four housing screws from the corners of the terminal box.
2. ➤ Lift off the terminal box cover.
3. ➤ Remove the blanks from the required bore holes
4. ➤ Guide the cables into the threaded connections
5. ➤ Connect the cables with the designated terminals.
6. ➤ Tighten the clamping nuts of the threaded connections so that they are properly sealed
7. ➤ Place the terminal box cover back onto the terminal box
8. ➤ Manually tighten the housing screws
9. ➤ Once again check the seating of the seals and threaded connections. Protection class IP 66 is only achieved if the control panel mounting is correct

5 Operating diagram

5.1 Overview of device /Control elements

- **Users' qualification:** Instructed person, see ↗ *Chapter 1.2 „Users' qualifications“ on page 8*

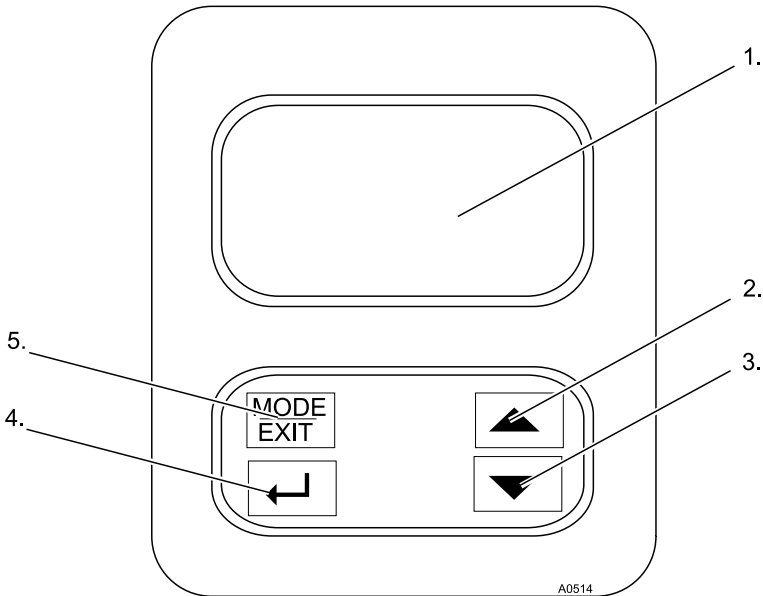

Fig. 5: Overview of device /Control elements

- | | |
|----------------|---------------------|
| 1. LCD display | 4. ENTER button |
| 2. UP key | 5. MODE/EXIT button |
| 3. DOWN key | |

Function	Description
LCD display	The parameters of the respective mode are shown on the LCD display.
UP key	To increase a displayed number

Function	Description
DOWN key	To decrease a displayed number
ENTER button	To apply, confirm or save a displayed value or status or
MODE/EXIT button	In order to call-up and select the three optional modes <i>[CAL]</i> , <i>[CONFIG]</i> and <i>[AUTO]</i> (measurement)

5.2 Overview of operating structure

The sensor is equipped with three modes, which can be selected by means of the MODE/EXIT button:

- *[AUTO mode]*: Standard mode, display of the current measured values
- *[CAL]*: Calibration mode for executing the calibration process
- *[CONFIG]*: Configuration mode for configuring customer-specific settings. Automatic switchover into the mode *[AUTO mode]* if no entry undertaken within 15 minutes

Operating diagram

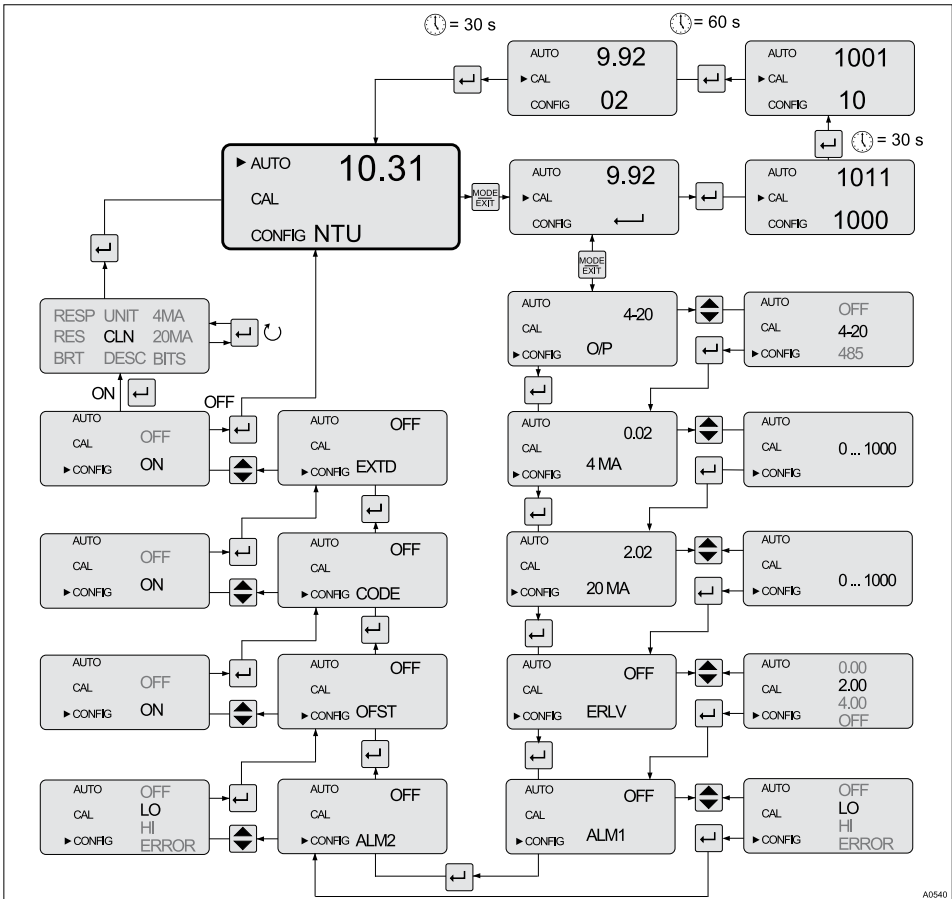

Fig. 6: Overview of operating structure

Configuration menu

The configuration menu is subdivided into several submenus, in order to facilitate configuration.

The following submenus are available:

- Select the output *[O/P]*
- Configuration of 4 ... 20 mA interface *[ERLV]*
- Configuration of the alarm *[ALM1 / ALM2]*
- Configuration of the offset *[OFST]*
- Configuration of access protection *[CODE]*
- Extended settings *[EXTD]*

The procedure for configuring the menu settings is described here [↪ Chapter 6.4 „Device configuration“ on page 35](#).

The extended settings are grouped together in order to prevent accidental alteration.

- Speed of response *[RESP]*
- Screen resolution *[RES]*
- LCD illumination brightness *[BRT]*
- Displayed units *[UNIT]*
- Ultrasonic cleaning *[CLN]*
- RS-485 parameters *[BITS]*
- Drying agent alarm *[DESC]*

The procedure for configuring the extended settings is described here [↪ Chapter 6.4.5 „Extended settings“ on page 43](#).

6 Commissioning

Unit NTU (optionally FNU)

NTU (Nephelometric Turbidity Unit) is a unit of measurement for measuring the turbidity of liquids. Alternatively, the measurement can be expressed as FNU (Formazine Nephelometric Unit), see ↗ „Units“ on page 48. The calculation is undertaken 1:1.

Measured values over 1000 NTU are outside of the sensor's measurement range. Measured values over 1100 NTU cause the display to flash and a message to be displayed warning of excessive measured values.

During normal operation of the sensor, an arrow is positioned next to *[AUTO]*. In this state, the lower row indicates the unit of measurement and the upper row shows the current measured value.

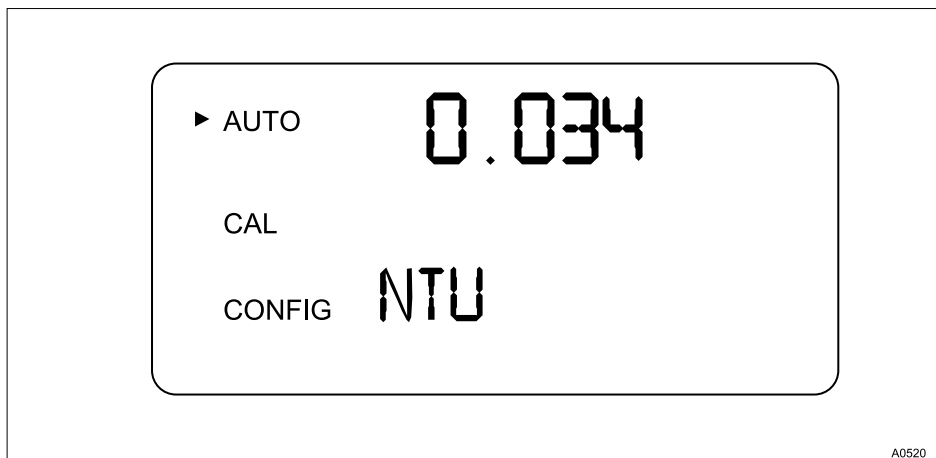

Fig. 7: Display in automatic mode

6.1 Load drying agent

Remove transport mounting

The transport mounting must be removed before initial insertion of the drying agent bag. This pipe can be subsequently disposed of.

The DULCO® turb C is equipped with an dehumidifying device. A drying agent bag in the sensor serves to dry the air. The thermal discharge from the sensor is used to heat the air. A fan mounted in the inner part of the sensor serves to circulate the warm air around the optical sleeve and cuvette. The DULCO® turb C continuously monitors the state of the drying agent bag. As soon as the drying agent needs to be exchanged, this is indicated in the lower row of the LCD display; Warning *[DESC]* (for desiccant). Replacement drying agent bags can be obtained from Prominent or from your local representative.

Saturated drying agent can cause an alarm to be triggered, in order to indicate the requirement for exchange. Refer to ☞ *„Drying agent alarm“ on page 51*

! NOTICE!

Seal sensor housing

Possibility of premature drying agent saturation.

A damaged seal can lead to premature saturation of the drying agent.

Check the seal every time the drying agent is exchanged. Correct the seal seating or exchange it if necessary.

1. Release the four screws from the corners of the housing and remove the upper part of the sensor

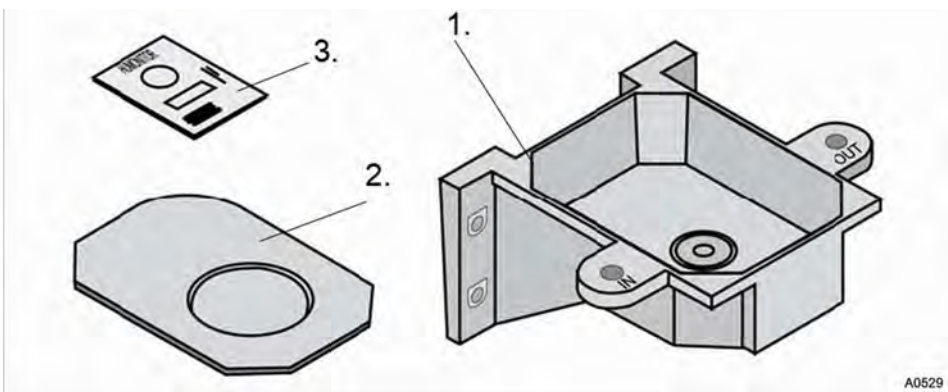

Fig. 8: Load drying agent

2. →



Insert the drying agent immediately after opening the packaging, in order to avoid premature saturation.

Remove the new drying agent bag (2) from the packaging and place it together with the humidity indicator card (3) in the lower part of the sensor (1). In doing so, place the humidity indicator card (3) on the new drying agent bag (2).

- 3.** → Place the upper part back on the lower part and tighten the four screws hand-tight.
- ⇒ The sensor must be reset in order to enable detection of the new drying agent. In order to do so, remove the sensor connection cable for 2 seconds and then re-connect it. Otherwise the *[DESC]* warning may be shown on the LCD display.

6.2 Routine measurement

Routine measurement: The turbidity can be correctly measured approx. 45 - 60 minutes after beginning measurement / commissioning (warm-up phase).

If a continuous process water flow passes through the sensor, then the sensor shows you the measured turbidity level of the sample on the LCD display. In addition, a 4-20 mA signal or a digital signal is given, depending on the selected option.

6.3 Access code



The access code cannot be changed.

You can activate the access code for the sensor in the configuration menu. If the access code is activated, then this is indicated in the lower right-hand section of the LCD display. „Security“-Symbol (1) displays, if you press the **[MODE/EXIT button]**.

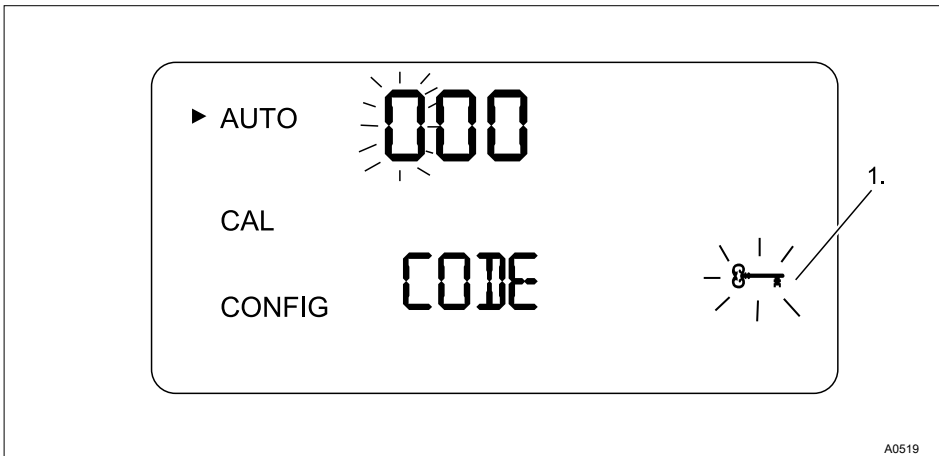



Fig. 9: Access code

When one of the access code numbers is flashing, you can change the number with the UP or DOWN button and confirm with the ENTER button.

Entering the access code

The access code (333) has to be entered in order to access the „CAL“ or „CONFIG“ menus.

1. ➔ The first number of the access code flashes. Select the correct number with the UP or DOWN button and then press ENTER
 - ⇒ The second number of the access code flashes.

2.  Select the correct number with the UP or DOWN button and then press ENTER
 - ⇒ The third number of the access code flashes.
3.  Select the correct number with the UP or DOWN button and then press ENTER
 - ⇒ If you have selected the valid access code, then you will now have access to the sensor's calibration mode. In the event that the access code is incorrect, the sensor returns to AUTO mode.

6.4 Device configuration

6.4.1 Selecting the output

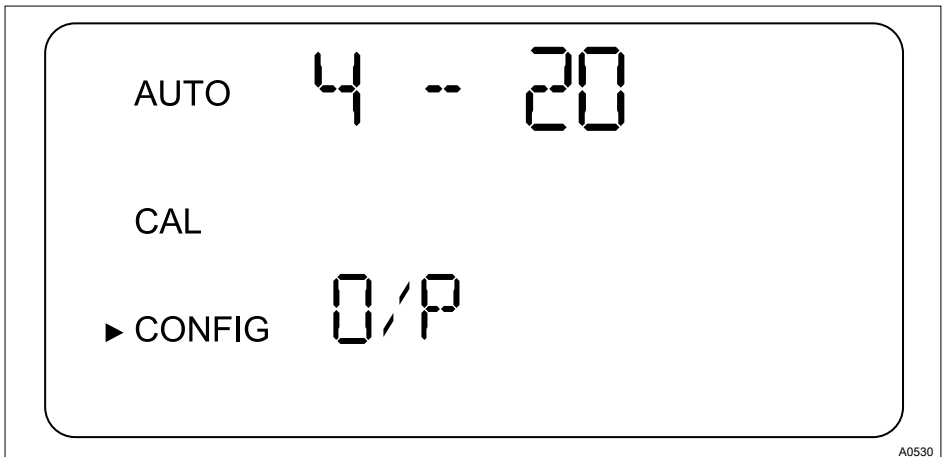

Fig. 10: Selecting the output

Commissioning

Function	Options	Info
Output (O/P)	<ul style="list-style-type: none"> ■ 4 - 20 mA ■ 485 ■ off 	
4 - 20 mA		
Value 4 mA	0 ... 1000 NTU	Selection of the lower turbidity limit value (LOLM)*, which corresponds to the output value 4 mA.
Value 20 mA	0 ... 1000 NTU	Selection of the upper turbidity limit value (UPLM)**, which corresponds to the output value 20 mA.
<p>* = a higher NTU value can be entered than for „value 20 mA“, in order to reverse the sign of the output current</p> <p>** = a lower NTU value can be entered than for „value 4 mA“, in order to reverse the sign of the output current</p>		
485		
Baud	Value baud <ul style="list-style-type: none"> ■ 1200 ■ 2400 ■ 4800 ■ 9600 ■ 19200 	Selection of the baud rate for the I/O interface

Function	Options	Info
Addr	1 ... 255	Selection of the device address
MBUS	ASCII RTU	Selection ASCII or RTU

6.4.2 Configuration of fault current (ERLV)

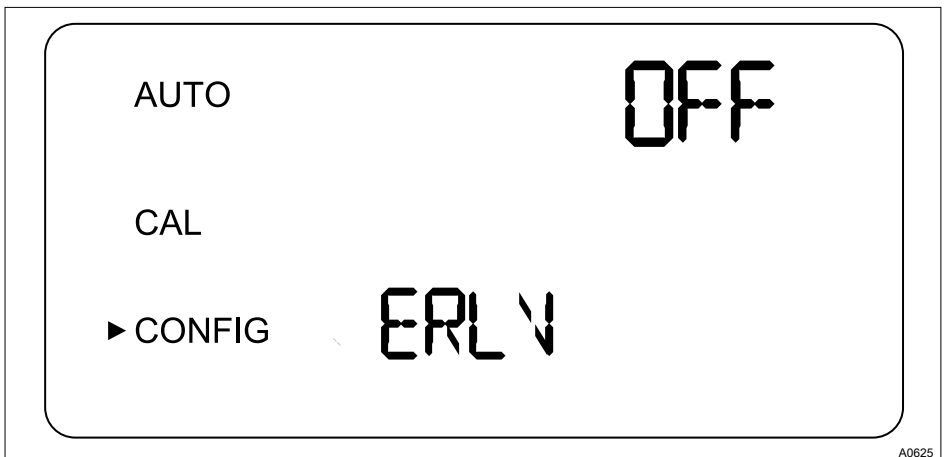

Fig. 11: Configuration of fault current (ERLV)

The 4-20 mA signal output can be utilized in the event of a system error on the DULCO® turb C in order to indicate the problem by activating the *[ERLV ON]* function. In doing so, fault currents of 4.00 mA, 2.00 mA or 0 mA can be selected. In the event of an error, the configured current value is output to the controller, regardless of which measured value is pending. If the function is switched off by setting *[OFF]* then the 4-20 mA signal output remains unaffected by fault conditions.

Select the desired fault current by pressing the buttons ▲ and ▼ and then press the ↵, in order to store the selected setting.

Function	Options	Info
Error Level (ERLV)	OFF 0 mA 2 mA 4 mA	

6.4.3 Configure alarm

The sensor is equipped with two independently programmable alarm relays. Three items of information have to be entered in order to fully configure the alarms:

- Alarm function: HI, LO, OFF or ERROR
- Alarm limit value (limit value at which the alarm becomes active)
- Alarm delay time (how long the limit value must be exceeded before the alarm is activated and the period of time before the alarm is reset)

Alarm function

 ***Alarm triggering in the event of an internal system error***

The relay produces an alarm in the event of an internal system error, regardless of the configured turbidity values.

You can either deactivate the alarm (OFF) or program it so that it works in accordance with one of the following modes:

- Alarm HI: The relay triggers the alarm in the event that the turbidity value exceeds the programmed alarm value for at least the specified period of time
- Alarm LO: The relay triggers the alarm in the event that the turbidity value drops below the programmed alarm value for at least the specified period of time
- Alarm ERROR: The relay triggers the alarm when an internal system error occurs

Limit value alarm

The turbidity threshold at which the alarm is triggered is referred to as the „*Limit value alarm*“. You can configure the limit value across the entire display range of the device in steps of 0.01 NTU.

Delay period alarm

The alarm delay times prevent the alarm from being triggered in the event that the turbidity briefly exceeds or drops below the threshold value. The delay function works as follows:

- Delay time „*Alarm on*“: The turbidity must exceed the „*Limit value alarm*“ for a period of at least the time configured here, before the alarm will be triggered. If the time for „*Delay alarm on*“ is set to 5 seconds and the turbidity only exceeds „*Limit value alarm*“ for 4 seconds, then the alarm will not be triggered. However, if the turbidity exceeds the „*Limit value alarm*“ for 5 seconds or longer, then the sensor triggers an alarm.
- Delay time „*Alarm off*“: The turbidity must drop below „*Limit value alarm*“ for a period of at least the number of seconds configured here, before the alarm will be triggered. If the time for „*Delay alarm off*“ is set to 5 seconds and the turbidity only exceeds „*Limit value alarm*“ for 4 seconds, then the alarm will not be deactivated. As soon as the turbidity remains below „*Limit value alarm*“ for at least 5 seconds, the sensor deactivates the alarm.

Menu Alarm



A0531

Fig. 12: Menu Alarm

Function	Options	Info
Alarm 1 (ALM1) or Alarm 2 (ALM2)	<ul style="list-style-type: none"> ■ HI ■ LO ■ OFF ■ ERROR 	Select the alarm function
Limit value (S/P)	0 ... 1000 NTU	Set the „ <i>Limit value alarm</i> “ on
delay time alarm on (DLY▲)	1 ... 30 s	For the function „ <i>Delay alarm on</i> “ set the number of seconds.
Delay time alarm off (DLY▼)	1 ... 30 s	For the function „ <i>Delay alarm off</i> “ set the number of seconds.

6.4.4 OFFSET configuration



The OFFSET symbol is shown as soon as an offset is being used. The maximum offset amounts to 1.00 NTU. If the device deviation is greater than 1 NTU, then it is recommended to carry out a complete calibration.

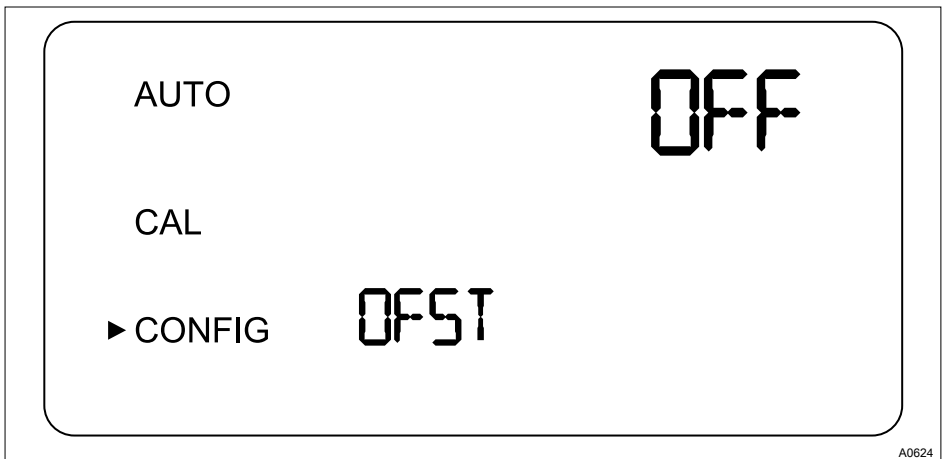









Fig. 13: OFFSET configuration

In certain circumstances it may be desirable to use an offset function in order to balance the device, instead of performing a complete calibration (as described under  *Chapter 7.1 „Calibrate sensor“ on page 55*). This procedure is not recommended as a replacement for regular calibration, however, it can be used in order to compensate for known minor deviations where measuring operations cannot be interrupted. This balancing method means that the device only displays precise turbidity values in the immediate vicinity of the sample value and not across the entire measured range.

Proceed as follows in order to configure the offset:

1.  Take a sample of the process water being monitored by the device and make a note of the turbidity as indicated by the device.
2.  Measure the turbidity value of the sample with the help of a calibrated manual laboratory measuring device (reference device)
3.  Compare the turbidity value indicated by the device with the value measured by the reference device. If the values are extremely close to each other (depending on the accuracy of the reference device), then no offset configuration or calibration is required and the procedure can be aborted at this point.
 - ⇒ However, if the values differ significantly (however, less than 1 NTU), then proceed as follows in order to improve the turbidity value for the device, so that the device matches the laboratory value.
4.  Select the offset function by pressing [*MODE/EXIT button*] until the arrow is positioned next to [*CONFIG*]
5.  Press the key \leftarrow , until [*OFST*] is shown in the lower row
 - ⇒ At this point, the upper row of the display indicates the operating condition of the offset function.
6.  If the function is switched off, then switch it [*ON*], by pressing \blacktriangledown or \blacktriangle .
7.  Select the desired offset value with \blacktriangledown or \blacktriangle
 - ⇒ Press the key \leftarrow , to accept the value.



The difference between the value measured by the DULCO® turb C NTU-value and the value measured by the reference device is the offset value.

For example, if the DULCO® turb C measures a value of 0.016 NTU for the process water, and the reference device measures a value of 0.012 NTU for the sample, then entering an offset value of -0.04 will cause the DULCO® turb C to display the value 0.012 NTU

8. ➤ At this point, the offset configuration is completed. At this stage, the device remains in configuration mode [CONFIG]. Press the key [MODE/EXIT button] in order to return to [AUTO]

6.4.5 Extended settings

Extended settings

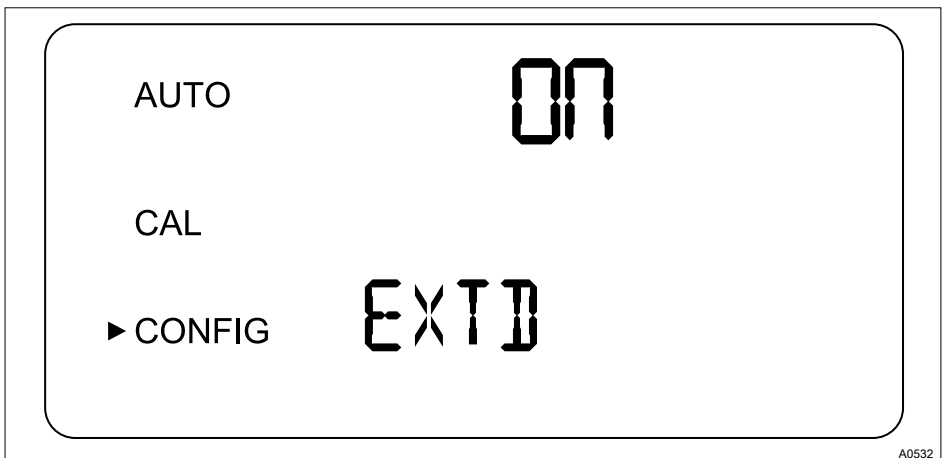
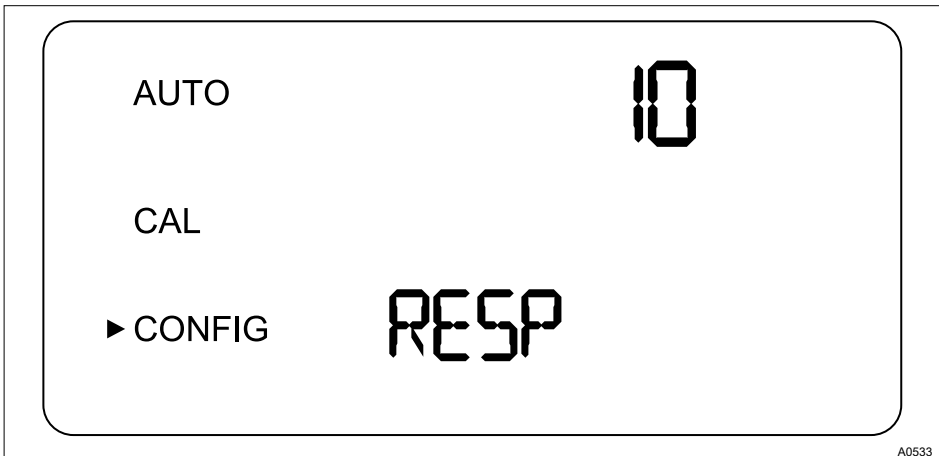

Fig. 14: Extended settings

Function	Options	Info
Extended settings	[ON] (On) [OFF] (Off)	Select the function "Extended settings" in order to access configuration for the following options: <ul style="list-style-type: none">■ Speed of response■ Screen resolution■ LCD illumination brightness■ Units■ Ultrasonic cleaning■ RS-485 parameters■ Alarm drying agent

Response time



A0533

Fig. 15: Response time

Function	Options	Info
Reaction time (RESP)	1 ... 100 % Factory setting: 10 %	<p>Select a reaction time for the displayed and output NTU values.</p> <p>Select the highest reaction time (i.e. the highest number) in order to avoid anomalies caused by air or other influences.</p> <p>Select the lowest reaction time (i.e. the lowest number) if rapid changes are to be expected, which are to be monitored.</p> <p>The displayed number is a relative reaction time. The approximate reaction time (in seconds) can be calculated by the displayed number multiplied by 5.</p>

Screen resolution

Fig. 16: Screen resolution

Function	Options	Info
Screen resolution (RES)	1 ... 0.001 Factory setting: 0,01	For displayed values under 10 NTU the DULCO® turb C is able to display a value with up to four digits after the decimal point

LCD illumination brightness

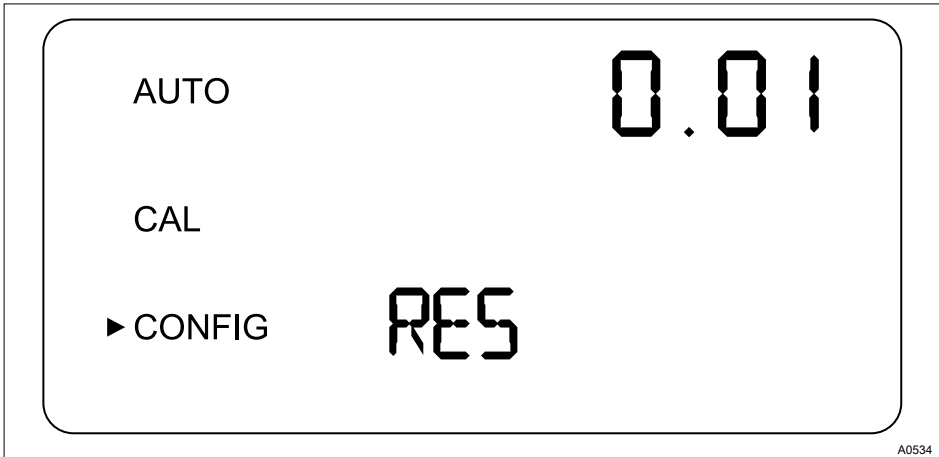
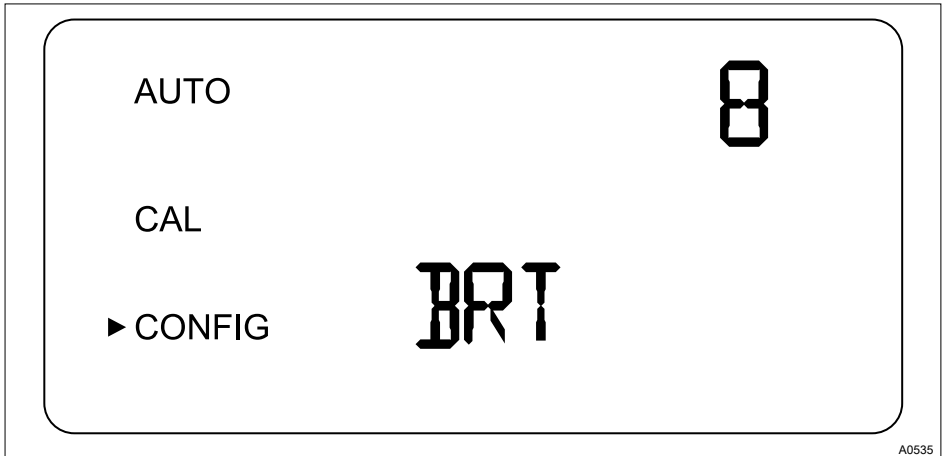
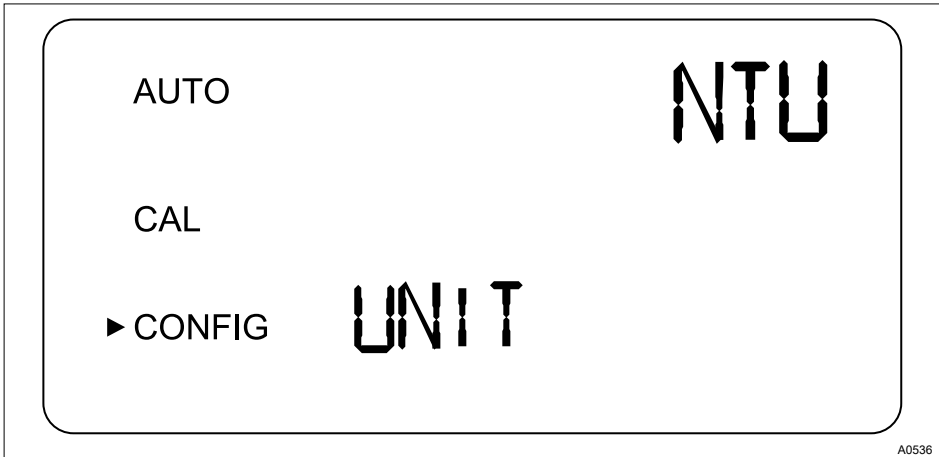

Fig. 17: LCD illumination brightness

Function	Options	Info
LCD illumination brightness (BRT)	1 ... 10 Factory setting: 8	Adjust the backlighting for the LCD display as required

Units



A0536

Fig. 18: Units

Function	Options	Info
Units (UNIT)	<ul style="list-style-type: none"> ■ NTU ■ FNU <p>Factory setting: NTU</p>	<p>Select a unit for displaying the turbidity measurement:</p> <p>NTU <i>[Nephelometric Turbidity Units]</i></p> <p>or</p> <p>FNU <i>[Formazin Nephelometric Units]</i></p>

Ultrasonic cleaning (models TUC 3 and TUC 4)

Error message in the event of incorrect cuvette

Only active if a corresponding cuvette with ultrasound transducer is used. If you use a cuvette without an ultrasound transducer, then an error message will be shown on the LCD display.

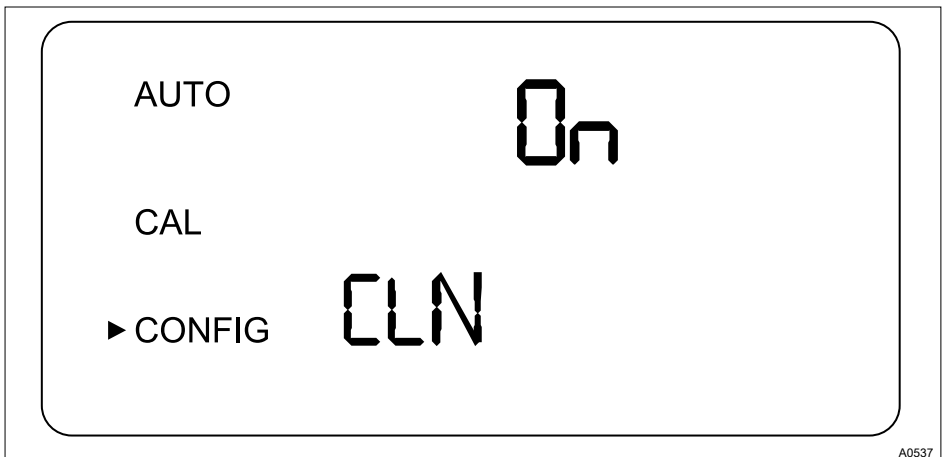

A0537

Fig. 19: Ultrasonic cleaning

Function	Options	Info
Ultrasonic cleaning (CLN)	[ON](On) [OFF](Off) Factory setting: [ON]	Switching the ultrasonic cleaning function on and off

If the ultrasonic cleaning function is working normally „*AUTO*“ flashes in automatic measuring mode (AUTO)

RS-485 parameters

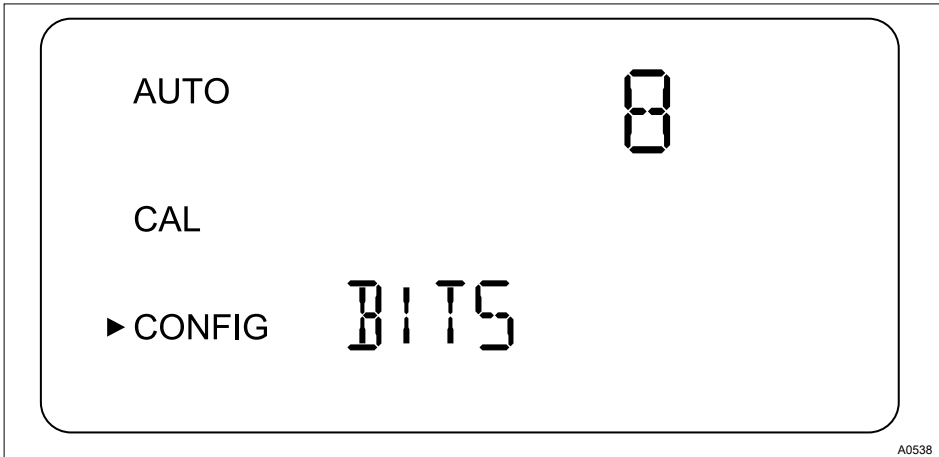
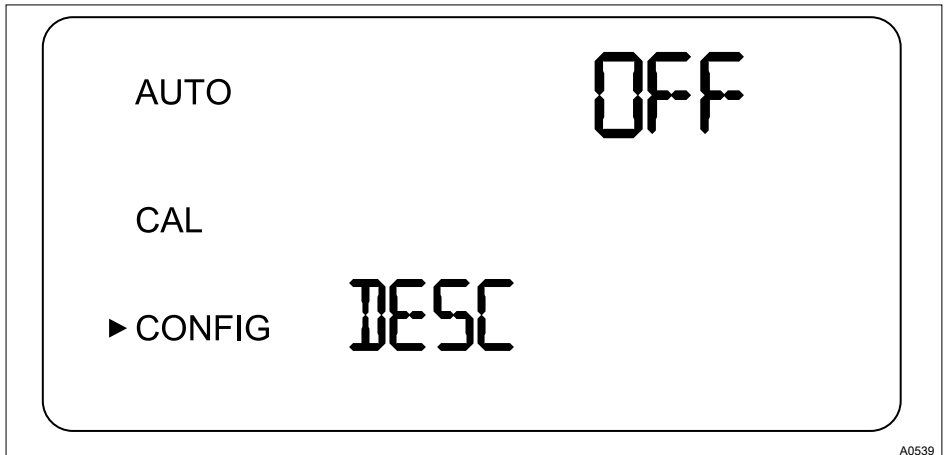

Fig. 20: RS-485 parameters

Function	Options	Info
Bits (BITS)	7 8 Factory setting: 8	The required number of data bits for the communications software deployed
Parity (PRTY)	nOnE ODD E Factory setting: nOnE	The parity bit required for the communications software.
Stop	1 2 Factory setting: 1	The stop bit required for the communications software.

Drying agent alarm



A0539

Fig. 21: Drying agent alarm

Function	Options	Info
Drying agent alarm (DESC)	[ON] (On) [OFF] (Off) Factory setting: [OFF]	Select [ON,] in order to trigger an alarm when the drying agent is saturated

In order to activate one or both alarms, then you must configure „ERROR“, see ↪ [Chapter 6.4.3 „Configure alarm “ on page 38.](#)

In order to indicate an error via the 4-20 mA signal, „ERROR ALARM (ERLV)“ must be selected in alarm current, see ↪ [Chapter 6.4.3 „Configure alarm “ on page 38.](#)

Configuration of 4 mA output

Allow a constant output of 4 mA and will allow you to calibrate or adjust the 4 mA signal.

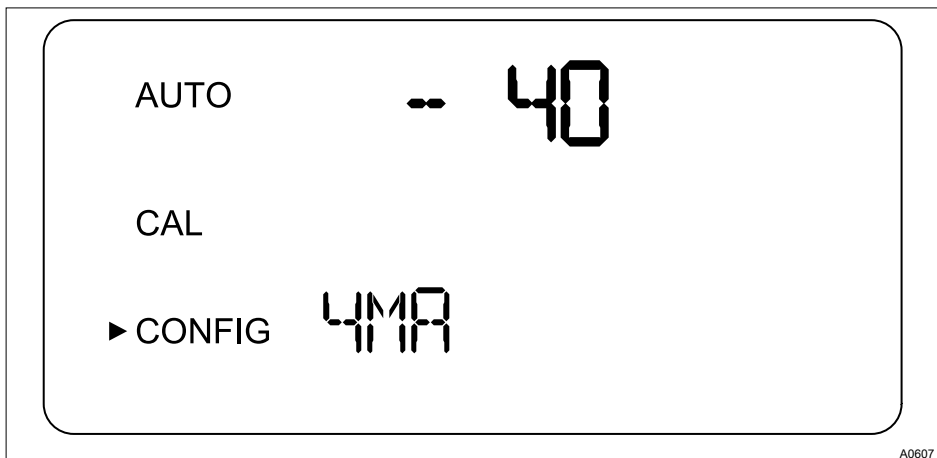

A0607

Fig. 22: Configuration of 4 mA output

Function	Options	Info
Configuration of 4 mA output	- 40 ... + 40	<p>Configure the mA value in order to adapt to the superordinated control system (e.g. SPC or SCADA)</p> <p>One count number corresponds to 0.01 mA</p>

Configuration of 20 mA output

Allow a constant output of 20 mA and will allow you to calibrate or adjust the 20 mA signal.

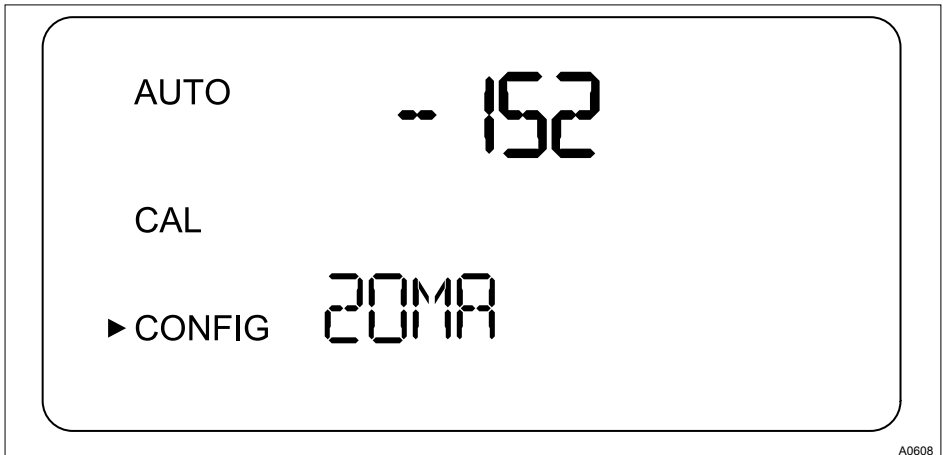

A0608

Fig. 23: Configuration of 20 mA output

Function	Options	Info
Configuration of 20 mA output	- 1000 ... + 1000	Configure the mA value in order to adapt to the superordinated control system (e.g. SPC or SCADA) One count number corresponds to 0.01 mA

Save configuration settings

If you have set the extended settings (EXTD) to „OFF“ then you can use the **[↵]** button to save the settings and return to the permanent display in „AUTO“ mode, see figure Fig. 6

If you have set the extended settings (EXTD) to „*ON*“ then you can use the *[↔]* button after the final menu in the extended settings to save your settings and return to the permanent display in „*AUTO*“ mode, see figure Fig. 6. All changes previously undertaken in the configuration menu can be stored in this manner.

You can access the configuration menu at any time in order to reset or modify some or all of the parameters. You can exit the configuration menu at any time by pressing the *[MODE/EXIT button]*. In doing so, any changes to the parameters that you have modified will be stored.

Flow controller

The flow controller (part number 1037880) limits high-pressure systems to a flow of less than 1 l/min.

7 Operation

7.1 Calibrate sensor



The sensor was tested and calibrated before leaving the factory. For this reason, you can use the sensor right away. Under normal conditions, it is recommended to carry out calibration at least once every three months.

The alarm relay switches over to alarm state if the sensor is in [CAL] or [CONFIG] mode. If no entry is made in [CAL] mode within a period of 15 minutes, the sensor automatically toggles back over to [AUTO] mode.

7.1.1 Standard solutions for calibration



If you operate the sensor across its entire measurement range from 0.02 NTU to 1000 NTU, then you must perform calibration with all three standard solutions (0.02 NTU, 10.0 NTU and 1000 NTU). If the sensor is only operated in measurement ranges under 10 NTU, then you may perform a simplified calibration with standard solutions 0.02 NTU and 10.0 NTU.

CAUTION!

Use of diluted formazine

Possible consequences: Inaccurate calibration. Malfunctions in dependent processes.

Diluted formazine is instable. Ensure that freshly prepared formazine solution is used when performing calibration.

If possible, use a standard solution from Prominent for calibration. These standard solutions are more stable than formazine and have a minimum shelf-life of 12 months. In doing so, observe the use-by-date on the standard solution packaging.

Indexing the standard solution with your cuvette

CAUTION!

Malfunction of the control circuit

Possible consequence: Poor end-product quality

Ensure that your controller or other measuring equipment is configured so that the indexing process does not lead to unintentional control functions in the measurement and control system. The controller connected to the sensor may not process the signals and use them for control purposes during indexing of the signals.

Calibration set order number:
1037699

NOTICE!

Screen resolution

We recommend indexing the DULCO® turb C in the "Commissioning / Display resolution" menu, so that the following resolution is achieved

- 1000 NTU: No digits after the decimal point on the display
- 10 NTU: Two digits after the decimal point on the display
- 0.02 NTU: Four digits after the decimal point on the display

i *Handling the standard solution*

The standard solution 1000 NTU must be lightly shaken before use for calibration.

Standard solution 10 NTU must be transferred to the cuvette from the supply bottle before it is used for the first time. The filling for the 10 NTU cuvette is then usable for 3 months.

Do not use the standard solution once the use-by-date has expired.

i *Purpose of indexing*

The standard solution cuvettes have minimal manufacturing tolerances. This results from the manufacturing process and is unavoidable.

In order to minimise the effects of these manufacturing tolerances on the calibration process, you must index and mark the position on the cuvette with the lowest turbidity value (lowest NTU value).

You can mark the index points with the help of the marking rings supplied. These marking rings are included with the calibration set packaging. The marking ring must first be placed around the plastic cover of the respective cuvette.

Prerequisites: The sensor is operational and is switched to *[AUTO]* mode.

1. ➤ Open the flow unit by screwing it clockwise and remove the in-line flow fitting from the cuvette.
2. ➤ Place the *[1000 NTU]* calibration cuvette in the DULCO® turb C
3. ➤ Rotate the *[1000 NTU]* calibration cuvette one full turn in 20° steps. On each step, wait until the displayed measured value has stabilised.
 - ⇒ Mark the point on the cuvette with the lowest NTU value with the help of the marking ring supplied, so that the marker points towards yourself.
4. ➤ Remove the *[1000 NTU]* calibration cuvette and place the *[10 NTU]* calibration cuvette in the DULCO® turb C
5. ➤ Rotate the *[10 NTU]* calibration cuvette one full turn in 20° steps. On each step, wait until the displayed measured value has stabilised.
 - ⇒ Mark the point on the cuvette with the lowest NTU value with the help of the marking ring supplied, so that the marker points towards yourself.

6. ➤ Remove the *[10 NTU]* calibration cuvette and place the *[0.02 NTU]* calibration cuvette in the DULCO® turb C
7. ➤ Rotate the *[0.02 NTU]* calibration cuvette one full turn in 20° steps. On each step, wait until the displayed measured value has stabilised.
 - ⇒ Mark the point on the cuvette with the lowest NTU value with the help of the marking ring supplied, so that the marker points towards yourself.
8. ➤ Place the cuvette sample with the cuvette into the DULCO® turb C
9. ➤ Close the in-line flow fitting by screwing it in an anticlockwise direction.
 - ⇒ The DULCO® turb C is in *[AUTO]* mode.



For subsequent calibration, place the calibration cuvette into the DULCO® turb C so that the marking ring marker points towards yourself.

7.1.2 Perform calibration

CAUTION!

Malfunction of the control circuit

Possible consequence: Poor end-product quality

Ensure that your controller or other measuring equipment is configured so that the calibration process does not lead to unintentional control functions in the measurement and control system. The controller connected to the sensor may not process the signals and use them for control purposes during calibration of the signals.

NOTICE!

Fan standstill

The sensor fan is switched off during the calibration process, in order to extend the service life of the drying agent.

The fan is switched on:

- during the calibration countdown
- after returning to *[AUTO]* mode.
- After 5 minutes without input from the operator
 - Whichever occurs first.

Keep the measurement chamber covered if no cuvette is inserted and only place a cuvette into the measurement chamber if it is completely dry, in order to avoid premature saturation of the drying agent.

! NOTICE!

Cleaning the cuvette

Possibility measurement value distortion

Before inserting the respective cuvette, it must be thoroughly cleaned with the cleaning cloth provided with the calibration set. Even minimal traces of foreign bodies on the surface of the cuvette can cause the measured result to be falsified.

Prerequisites: The sensor is operational and is switched to *[AUTO]* mode.

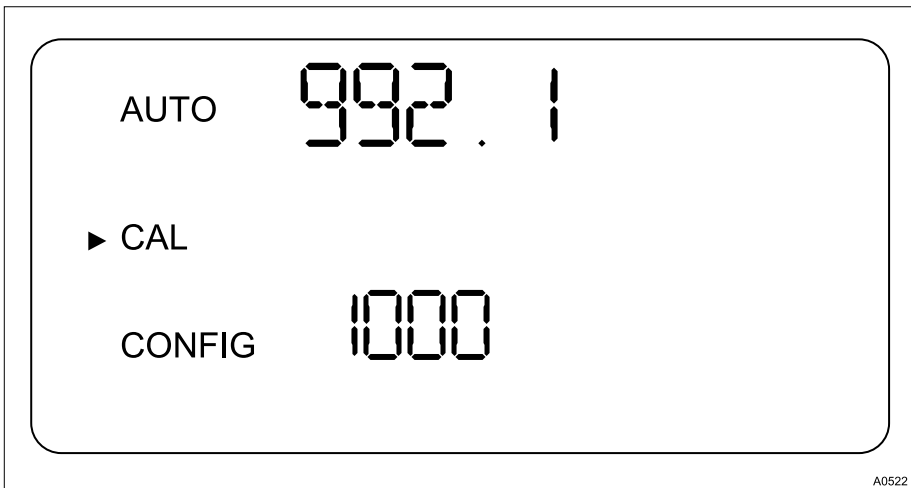

Fig. 24: Display [Calibration 1000 NTU]

1. ➔ Use the *[MODE/EXIT button]* key to select *[CAL]* mode.
 - ⇒ The LCD display (see Fig. 24) shows an arrow next to *[CAL]*. The lower display value (1000) is the selected calibration point. The upper displayed value is the currently measured NTU value.
2. ➔ Open the flow unit by screwing it in a clockwise direction and remove the cuvette sample together with the cuvette.

3. ➤ Place the [1000 NTU] calibration cuvette in the DULCO® turb C so that the marking ring marker points towards yourself, see
 ↪ „Indexing the standard solution with your cuvette“ on page 56
4. ➤ Slowly rotate the calibration cuvette 20° from the centre point to the left and then 20° from the centre point to the right
 ⇒ Leave the calibration cuvette in the position with the lowest measured value.

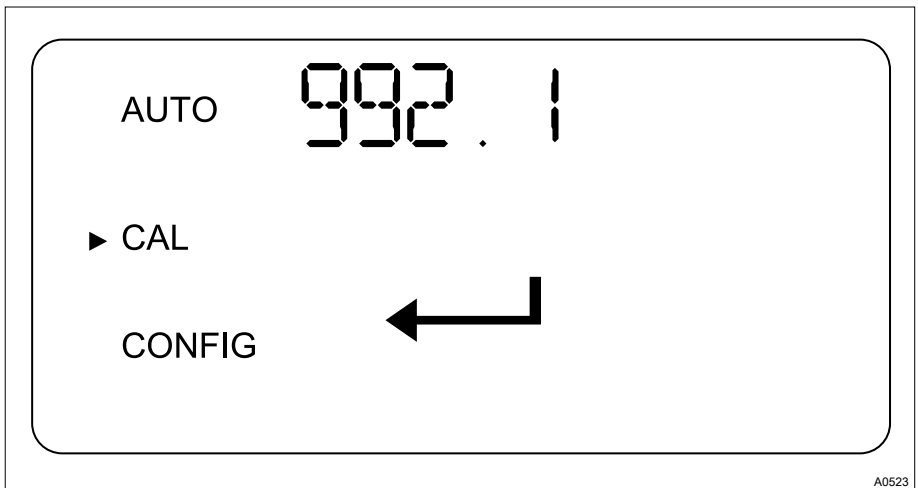

Fig. 25: Display [Start calibration]

5. ➤ Press the ↵-key in order to start calibration to [1000 NTU]
 ⇒ A 30 second countdown begins, after which the DULCO® turb C is calibrated to [1000 NTU].

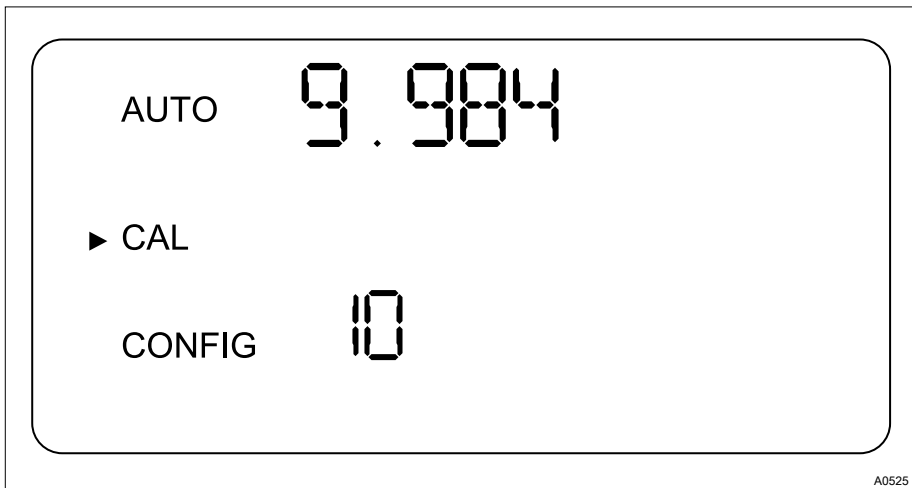

Fig. 26: Display [Calibration 10 NTU]

6. ➔ Remove the [1000 NTU] Calibration cuvette
7. ➔ Place the [10 NTU] calibration cuvette in the DULCO® turb C so that the marking ring marker points towards yourself, see
↳ „Indexing the standard solution with your cuvette“ on page 56
8. ➔ Slowly rotate the calibration cuvette 20° from the centre point to the left and then 20° from the centre point to the right
 - ⇒ Leave the calibration cuvette in the position with the lowest measured value.

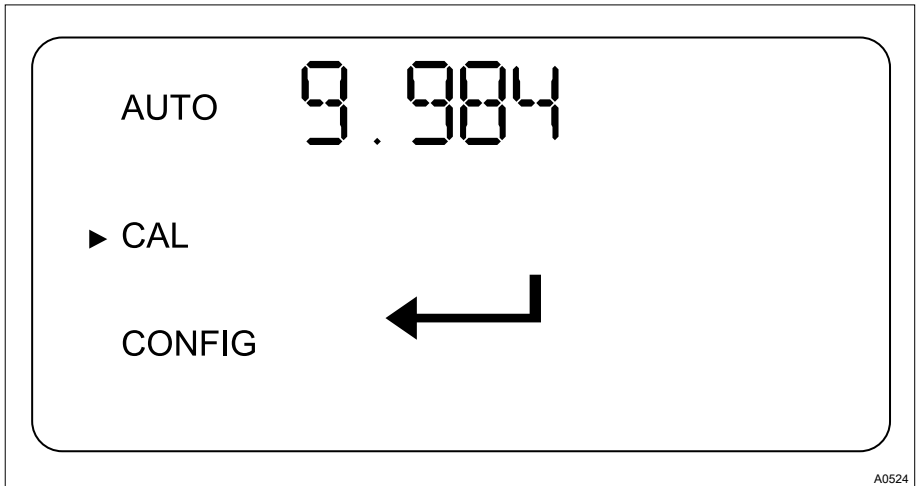

Fig. 27: Display [Start calibration]

9. Press the \leftarrow -key in order to start calibration to [10 NTU]

⇒ A 60 second countdown begins, after which the DULCO® turb C is calibrated to [10 NTU].

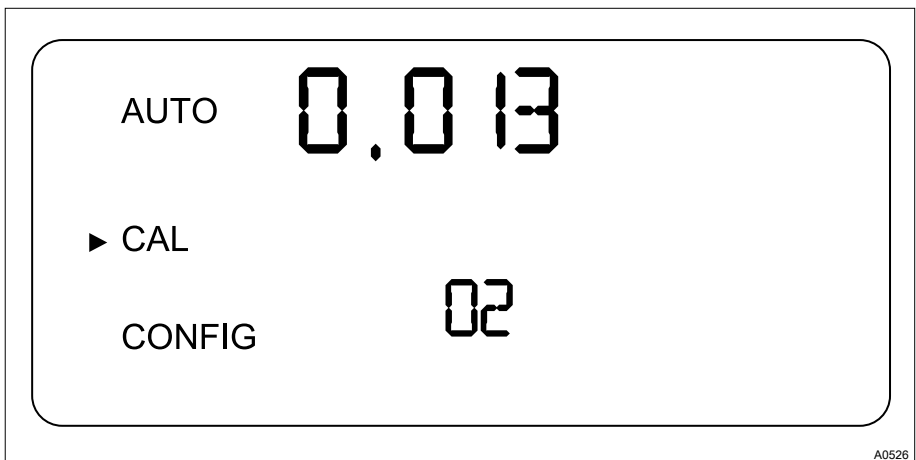

Fig. 28: Display [Calibration 0.02 NTU]

10. Remove the [10 NTU] Calibration cuvette

11. Place the [0.02 NTU] calibration cuvette in the DULCO® turb C so that the marking ring marker points towards yourself, see
↳ „Indexing the standard solution with your cuvette“ on page 56
12. Slowly rotate the calibration cuvette 20° from the centre point to the left and then 20 ° from the centre point to the right
⇒ Leave the calibration cuvette in the position with the lowest measured value.

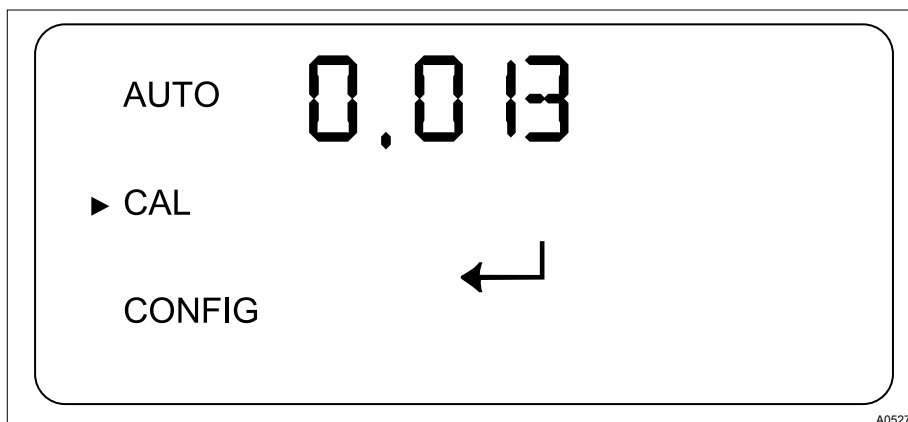

Fig. 29: Display [Start calibration]

13. Press the ↵-key in order to start calibration to [0.02 NTU]
⇒ A 30 second countdown begins, after which the DULCO® turb C is calibrated to [0.02 NTU].
14. Remove the [0.02 NTU] calibration cuvette from the DULCO® turb C
15. Place the cuvette sample with the cuvette into the DULCO® turb C.
16. Close the in-line flow fitting by screwing it in an anticlockwise direction
⇒ The DULCO® turb C is now calibrated and is returned to [AUTO] mode.

Incorrect calibration

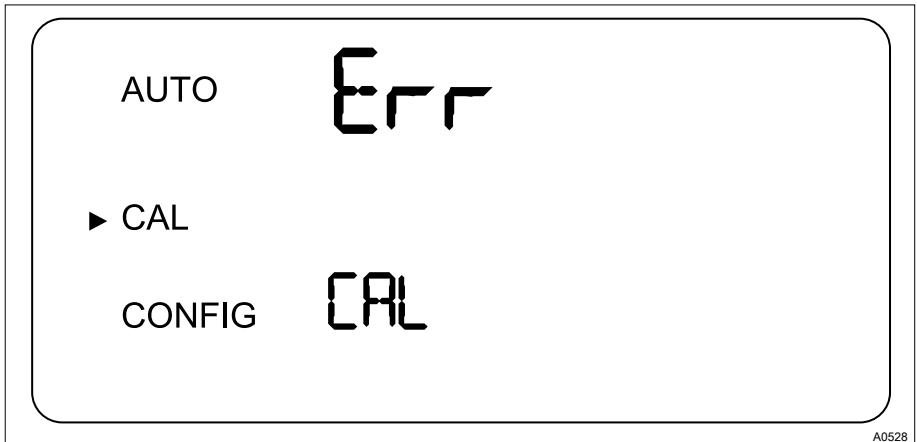

Fig. 30: Display [Incorrect calibration]

If the *[Err CAL]* message is shown, then the DULCO® turb C internal diagnostics system has determined that an error has occurred during calibration.

Press the *[MODE/EXIT button]* in order to repeat the calibration process.

Restoring the factory calibration settings

1. ▶ In order to restore the factory calibration, press and hold the ▲-key
2. ▶ Now press the ↵-key and release it again
3. ▶ Now release the ▲-key.
 - ⇒ The sensor will now work with the factory calibration values.

8 Maintenance, troubleshooting and repair

8.1 Information about fault maintenance

The sensor continuously carries out self-diagnostic checks. Any errors are displayed in the bottom row of the display.

The sensor has a three-stage fault detection system:

■ Warning

- A warning is merely a message on the display which serves to indicate a pending problem. No alarms are issued. For example, if the drying agent alarm is deactivated and the drying agent is saturated, the LCD display shows the following warning:
[DESC]

■ Fault

- An error indicates a malfunction or problem which can generally be rectified by the operator. This includes, for example, a lamp failure *[LAMP]* or incorrect calibration *[CAL]*. If an error occurs, the sensor continues to indicate

values, however, the accuracy of these measured values is uncertain, meaning that you cannot rely on the values given.

■ Malfunction

- A malfunction is a system error. This problem cannot be rectified by the operator. The sensor must be sent back to the factory for repair. These faults relate to malfunctions in the *[CPU]*, *[A/D]*, *[EEPROM]* or other units, which are integrated into the sensor. In the case of malfunction, the device will no longer work correctly and the message *[FAIL]* will be shown on the LCD display. Both alarm relays are activated and the current output is set to 2 mA.

8.1.1 System error messages

Fault message	Possible cause	Measure
[MA]	4 ... 20 mA circuit open	Check cabling
[DESC]	Drying agent saturated	Exchange drying agent. Refer to ↗ <i>Chapter 6.1 „Load drying agent“ on page 30</i>
[LAMP]	Lamp failure	Exchange lamp. Contact customer service
[FLOW]	Flow interrupted	Establish flow
[CLN]	Cuvette ultrasound transducer has no contact	Rotate the cuvette slightly in order to improve contact. Exchange the cuvette if the problem persists.
	Cuvette removed	Insert cuvette
[FAIL]	Fatal system errors	Contact customer service

8.1.2 Faults in the process

Fault	Possible cause	Process error
Displayed values higher than expected	Air bubbles in the sample water	Ensure that the outlet bleed valve is open and not blocked Create backpressure Install air bubble trap, accessories, order number 1037790
	Condensate or cuvette not airtight	Check cuvette for condensate or leaks
	Cuvette soiled	Clean cuvette

Fault	Possible cause	Process error
	Sensor not correctly calibrated	Calibrate sensor, see ↗ <i>Chapter 7.1.2 „Perform calibration“ on page 59</i>
Displayed values incorrect	Air bubbles in the sample water	Ensure that the outlet bleed valve is open and not blocked Create backpressure Install air bubble trap, accessories, order number 1037790
	Particles of dirt in the cuvette	Clean the cuvette of any particles of dirt.
Displayed values lower than expected	Sensor not correctly calibrated	Calibrate sensor, see ↗ <i>Chapter 7.1.2 „Perform calibration“ on page 59</i>
Upper row of display flashes	Sample has exceeded the permissible measurement range	Check sample. Turbidity of the sample may be too high in order to be read by the sensor

9 Spare parts and accessories

Spare parts

Spare part	Part number
Drying agent	1037701
Cuvette TUC1 / TUC2	1037877
Cuvette TUC3 / TUC4	1037878
Infrared lamp TUC1 / TUC3	1037702
White light lamp TUC2 / TUC4	1037703
Hose kit	1037879
Pressure regulating valve	1037885

Accessories

Accessories	Part number
Calibration set	1037699
Flow controller	1037880
Air bubble trap	1037700

10 Standards complied with

EN 60529 Specification for degrees of protection provided by enclosures (IP-Code)

EN 60746-1 Expression of performance of electrochemical analyzers - Part 1: General

EN 61000 Electromagnetic compatibility (EMC)

EN 61010 Safety requirements for electrical equipment for measurement, control and laboratory use - Part 1: General requirements

EN 61326 Electrical equipment for measuring, control and laboratory use - EMC requirements (for class A and B devices)

11 Disposal of used parts

- **Users' qualification:** instructed persons, see ↪ *Chapter 1.2 „Users' qualifications“ on page 8*

! NOTICE!

Regulations governing disposal of used parts

- Note the current national regulations and legal standards which apply in your country

ProMinent Dosiertechnik GmbH, Heidelberg will take back decontaminated used devices providing that they are covered by adequate postage.

12 Declaration of Conformity

EC Declaration of Conformity

We hereby declare,

ProMinent Dosiertechnik GmbH
Im Schuhmachergewann 5 - 11
D - 69123 Heidelberg

that the following designated product complies with the pertinent fundamental safety and health requirements of the EC Directive in terms of its design and construction and in terms of the version marketed by us. This declaration loses its validity in the event of a modification to the product not agreed with us.

Description of the product: **DULCOturb C**

Product type: **TUC1, TUC2, TUC3, TUC4**

Serial no.: refer to nameplate on the device

Pertinent EC Directives: EC Low Voltage Directive (2006/95/EC)
EC EMC Directive (2004/108/EC)

Applied harmonised standards in particular: **EN 61010-1, EN 61326**

technical documents have been compiled by: Norbert Berger
Im Schuhmachergewann 5-11
DE-69123 Heidelberg

Date / Manufacturer - Signature : 08.09.2010



Details of the signatory: Joachim Schall, Head of Research and Development

Fig. 31: Declaration of Conformity

13 Index

A		M	
Accessibility.....	17	Menu Alarm.....	40
Accessories.....	69	Mounting position.....	17
Alarm delay period.....	39	N	
Alarm ERROR.....	39	non-discriminatory approach.....	3
Alarm function.....	38	NTU.....	30
Alarm HI.....	39	O	
Alarm limit value.....	39	Operating position.....	17
Alarm LO.....	39	P	
Alarm menu.....	40	Pressure.....	21
Ambient temperature.....	17	Protection class IP 66	25
C		R	
Calibration erroneous.....	65	Radiant exposure.....	17
D		Reading position.....	17
Data.....	6	Recycling.....	16, 17
Delay period alarm.....	39	S	
F		Safety information.....	6
Flow.....	21	Spare parts.....	69
FNU.....	30	Strain relief.....	24
Functions.....	6	T	
G		Turbidity threshold.....	39
General non-discriminatory approach.....	3	U	
I		Unit NTU	30
Incorrect calibration.....	65	Users' qualifications.....	8
L			
Limit value alarm.....	39		
Liquid temperature.....	21		

